



MULTIPLE SYSTEMS, INC.

P.O. Box 15025
Amarillo, TX 79105-5025 USA
806-373-7073 Tel
806-373-7631 Fax

www.multiplesystems.com

Multiple Systems philosophy is to provide our customers with the highest quality products at the lowest possible price, with personal attention to each and every detail to ensure timely accurate service.

We have built our business on this concept and since our establishment in 1980; we continue to seek ways to improve our service to our business partners, our customers.

Custom / Design Services

Our Research and Development team works directly with the client to tackle specific engineering and operational problems to fabricate the custom parts and equipment required to eliminate down time.

We utilize an in-house drafting staff equipped with the latest CAD software to design, draft and document all fabrications and custom machining.

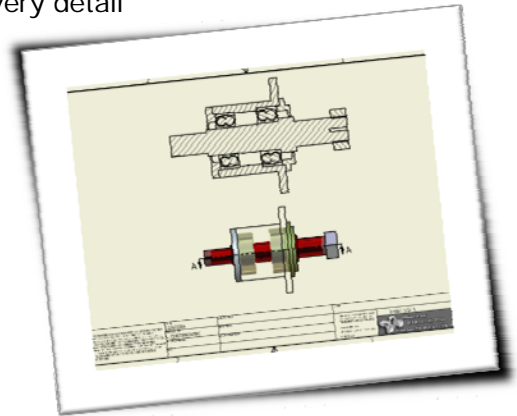

Fabrication Services



Our fabrication department is ready to build, per your specifications, or those special projects. Our qualified fabricators and welders can shear, break and weld stainless steel and carbon steel. Our personnel utilize the vertical shear and iron worker, bending rolls and forming rolls to fabricate your requirement in our fabrication shop.

Machining

Services

If you require machining services, Multiple Systems, Inc.'s fully functional machine shop is equipped with the machinery to get the job done. Many metal types are stocked at our facility including, carbon steel, stainless steel, stress-proof, hex, mechanical tube, chrome rod, brass rod and brass tube. Parts are custom manufactured on-site from professional drawings, sketches, email drawings and phone requests.

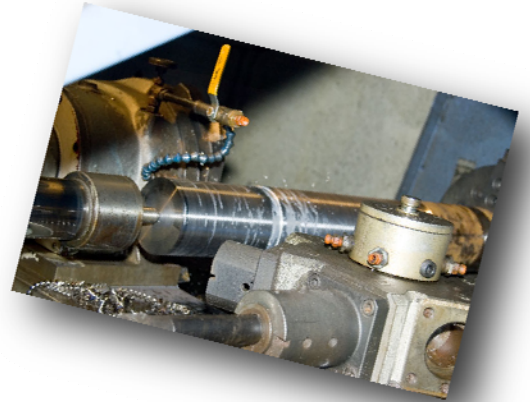



MULTIPLE SYSTEMS, INC.

P.O. Box 15025
Amarillo, TX 79105-5025 USA
806-373-7073 Tel
806-373-7631 Fax

www.multiplesystems.com

Repair Services



If you need repair services, Multiple Systems, Inc. 's repair technicians are available 24 hours daily and are capable of repairing your air and hydraulic cylinders, hydraulic pumps and motors, speed reducers, gearboxes, blowers and vacuum pumps and other industrial equipment.



Inventory Products

Our warehouse stocks a large selection of industrial items with over 15,000 individual line items to ensure rapid response to the material needs of your company.

We carry many types and sizes of bearings - mounted, un-mounted, ball, roller, spherical and tapered; seals, bushings, o-rings, poly-seals, fasteners, hydraulic and pneumatic fittings;

speed reducers, electric motors, hydraulic and pneumatic cylinders; hydraulic motors and pumps, hydraulic power units, hydraulic and pneumatic valves, machine parts, kits; modular conveyor belting, hinge pins, sprockets, drive shafts and tail shafts; HDPE and stainless sheet, steel products in stainless steel and carbon steel-angles, rounds, tubes, flats, channels, DOM and chrome rod.

